



# ESP8266-S3 WiFi Module Datasheet

Version 1.0

2017 / 9

## Disclaimer and Copyright Notice

Information in this document, including URL references, is subject to change without notice.

THIS DOCUMENT IS PROVIDED AS IS WITH NO WARRANTIES WHATSOEVER, INCLUDING ANY WARRANTY OF MERCHANTABILITY, NON-INFRINGEMENT, FITNESS FOR ANY PARTICULAR PURPOSE, OR ANY WARRANTY OTHERWISE ARISING OUT OF ANY PROPOSAL, SPECIFICATION OR SAMPLE. All liability, including liability for infringement of any proprietary rights, relating to use of information in this document is disclaimed. No licenses express or implied, by estoppel or otherwise, to any intellectual property rights are granted herein.

The WiFi Alliance Member Logo is a trademark of the WiFi Alliance.

All trade names, trademarks and registered trademarks mentioned in this document are property of their respective owners, and are hereby acknowledged.

## Note

As the product upgrade or other reasons, this manual may change. Shenzhen Hysiry Technology Co., Ltd has right to modify the contents of this manual without any notice or warning. This manual is only as a guide, Hysiry Technology Co., Ltd spare no effort to provide accurate information in this manual, but Hysiry can't guarantee manual there is no problem, all statements in this manual, information and suggestions do not constitute any guarantee of express or implication.

## Amendment record

Time	Version	Specification
2017.09	V1.0	First release

---

## Contents

1. Overview.....	4
2. Main Features.....	4
2.1 System Diagram.....	4
2.2 Hardware Specifications.....	5
3. Pin description.....	6
4. Functional Description.....	7
4.1 MCU.....	7
4.2 Memory.....	7
4.2.1 Internal SRAM and ROM.....	7
4.2.2 SPI Flash.....	7
4.3 Interface Description.....	8
5. Electrical Characteristic.....	9
5.1 Standby Power Consumption.....	9
5.2 RF Performance.....	10
5.3 Digital Terminal Characteristics.....	11
5.4 Absolute Maximum Ratings.....	11
5.5 Reflow Profile.....	11
6. Schematics.....	12
7. Minimum System Requirements.....	12
8. Switching noise control.....	13
9. Technical Support.....	13

## 1. Overview

ESP8266-S3 Wi-Fi module is a low consumption, high performance Wi-Fi network control module designed by Hysiry. It can meet the IoT application requirements in smart power grids, building automation, security and protection, smart home, remote health care etc.

The module's core processor ESP8266 integrates an enhanced version of Tensilica's L106 Diamond series 32-bit processor with smaller package size and 16 bit compact mode, main frequency support 80 MHz and 160 MHz, support RTOS, integrated Wi-Fi MAC / BB / RF / PA / LNA, on-board PCB antenna.

The module supports standard IEEE802.11 b / g / n protocol, a complete TCP / IP protocol stack. Users can use the module to add networking capabilities to existing devices, but also to build an independent network controller.

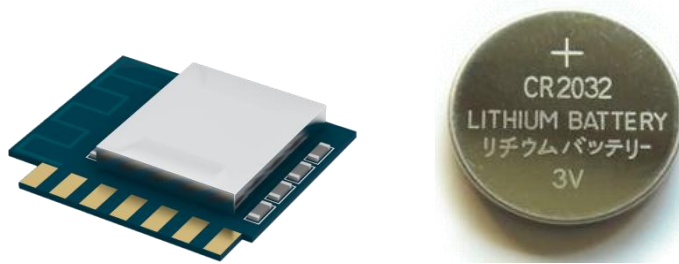

Figure -1.ESP8266-S3 Module

## 2. Main Features

### 2.1 System Diagram

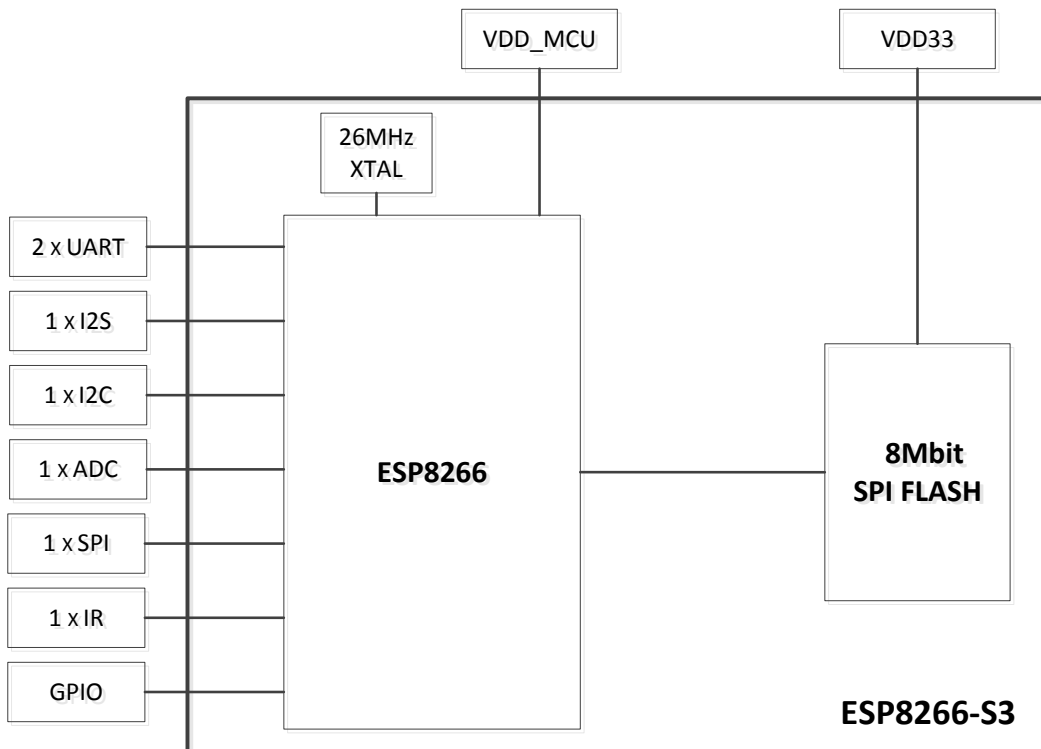

Figure -2. System Diagram

## 2.2 Hardware Specifications

- Operating Voltage: 3.3V (3.0 ~ 3.6V)
- Operating Temperature: -40 - 85°C
- CPU Tensilica L106
  - RAM 50KB (Available)
  - Flash 8 Mbit
- System
  - 802.11 b/g/n
  - Frequency range 2.4 GHz ~ 2.5 GHz (2400 M ~ 2483.5 M)
  - Integrated Tensilica L106 ultra-low power 32-bit micro MCU, with 16-bit RSIC. The CPU clock speed is 80MHz. It can also reach a maximum value of 160MHz.
  - WIFI 2.4 GHz, support WPA/WPA2
  - Supports UART、I2C、GPIO、PWM、SDIO、SPI、ADC、PWM、IR
  - Integrated 10 bit high precision ADC
  - Supports TCP、UDP、HTTP、FTP
  - Integrated TR switch, balun, LNA, Power amplifier and matching network
  - Integrated PLL, Regulator and power source management components, +20 dBm output power in 802.11b mode
  - Average working current 80mA, <Deep sleep current < 20uA, Power down leakage current < 5uA
  - Rich interface on processor: SDIO 2.0, SPI, UART
  - Wake up , build the connection and transmit packets in < 2ms
  - Standby power consumption < 1.0mW (DTIM3)
  - Support AT remote upgrades and cloud OTA upgrade
  - Support Station / SoftAP / SoftAP+Station operation modes
  - Ultra-Small 20.2mm \* 17.6mm \* 3.05mm

**3. Pin description**

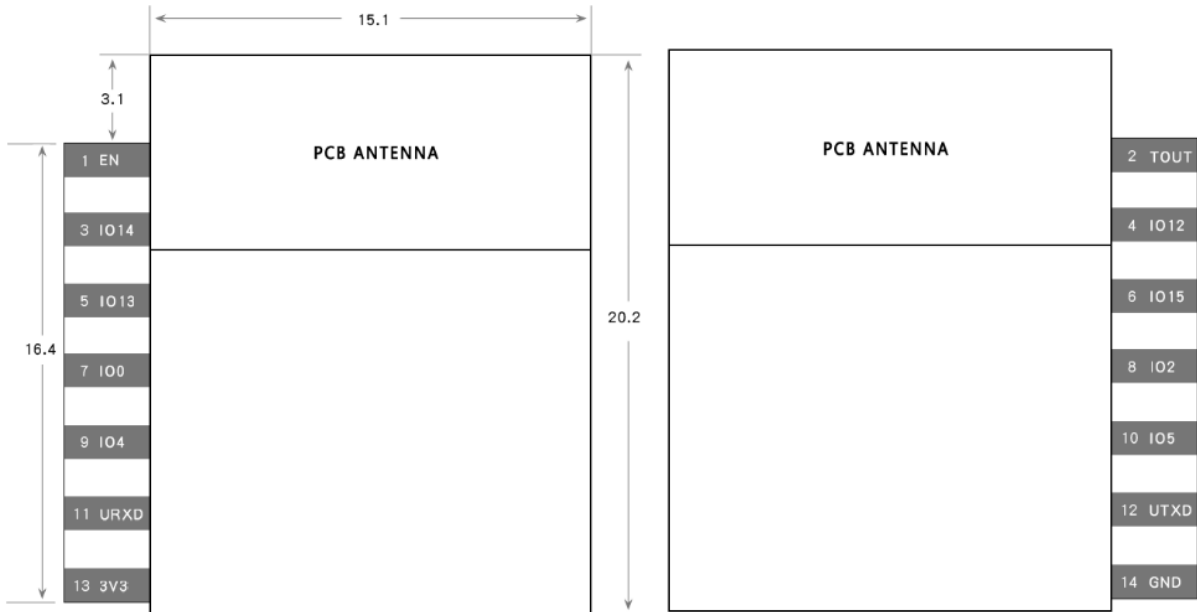

Figure -3. Pin description



Figure -4. Module Size - shieldingcase (Side View)

Table -1. ESP8266-S3 Pin Definitions

No.	Pin Name	Functional Description
1	EN	Chip enable pin (cannot be floating). Active high.
2	TOUT	Tests the power-supply voltage of VDD3P3 and the input power voltage of TOUT. These two functions cannot be used simultaneously.
3	IO14	GPIO14; HSPI_CLK
4	IO12	GPIO12; HSPI_MISO
5	IO13	GPIO13; HSPI_MOSI; UART0_CTS
6	IO15	GPIO15; MIDO; HSPICS; UART0_RTS
7	IO0	GPIO0 <ul style="list-style-type: none"> <li>• UART download: pull down.</li> <li>• SDIO boot: don't-care.</li> </ul>
8	IO2	GPIO2; UART1_TXD

9	IO4	GPIO4
10	IO5	GPIO5
11	URXD	UART0_RXD, receive end in UART download; GPIO3
12	UTXD	UART0_TXD, transmit end in UART download, floating (internal pull-up) or pull up; GPIO1
13	VCC	3.3 V power supply (VDD) <b>Note:</b> It is recommended the maximum output current a power supply provides be of 500 mA or above.
14	GND	Ground

**4. Functional Description**

**4.1 MCU**

ESP8266EX contained in the ESP8266-S3 integrates Tensilica L106 32-bit micro controller (MCU) and a 16-bit RSIC. The CPU clock speed is 80 MHz and can reach a maximum value of 160 MHz. The system can readily run a Real Time Operating System (RTOS). Currently, the Wi-Fi stack only takes up 20% of CPU time. The remaining CPU time (80% of total MIPS) can be used for user application. The MCU can work in conjunction with the other parts of the chip through the following interfaces.

- Programmable RAM/ROM interface (iBus) that connects to memory controller and can access the external flash.
- Data RAM interface (dBus) that connects to memory controller.
- AHB interface that accesses the register.

**4.2 Memory**

**4.2.1 Internal SRAM and ROM**

ESP8266EX Wi-Fi SoC integrates memory controller including SRAM and ROM. MCU can access the memory controller through iBus, dBus, and AHB interfaces. All these interfaces can access ROM or RAM units. A memory arbiter determines the running sequence in the arrival order of requests.

According to our current version of SDK, SRAM space available to users is assigned as below.

- RAM size < 50 kB, that is, when ESP8266EX is working in Station mode and connects to the router, available space in Heap + Data sector is around 50 kB.
- There is no programmable ROM in ESP8266EX, therefore, user program must be stored in the SPI flash integrated into the ESP8266-S3.

**4.2.2 SPI Flash**

- ESP8266EX supports SPI flash. Theoretically speaking, ESP8266EX can support up to 16 MB SPI flash.
- ESP8266-S3 currently integrates 8 Mbit SPI flash memory. ESP8266-S3 supports these SPI modes:

Standard SPI, DIO (Dual I/O), DOUT (Dual Output), QIO (Quad I/O) and QOUT (Quad Output).

**4.3 Interface Description**

Table -2. Interface Description

Interface	Pin	Functional Description
SPI	IO12(MISO),IO13(MOSI), IO14(CLK),IO15(CS)	S3 can control SPI Slave as a Master or communicate with Host MCU as a Slave. In overlap mode, S3 can share the SPI interface with Flash, shifted by different CS signals.
PWM	Any available GPIO (EXCEPT GPIO16)	Currently the demo provides 4 PWM channels (users can extend to 6 channels). PWM interface can realize the control of LED lights, buzzers, relays, electronic machines, etc.
IR	Any available GPIO (EXCEPT GPIO16)	The functionality of Infrared remote control interface can be implemented via software programming. NEC coding, modulation, and demodulation are used by this interface. The frequency of modulated carrier signal is 38KHz.
ADC	TOUT	ESP8266EX integrates a 10-bit precision SAR ADC. ADC_IN interface is used to test the power supply voltage of VDD3P3 (Pin 3 and Pin 4), as well as the input voltage of TOUT (Pin 6). It can be used in sensors application.
I2C	IO14(SCL), IO2(SDA) Any available GPIO (EXCEPT GPIO16)	Can connect to external sensor and display, etc.
UART	UART0: TXD(U0TXD),RXD(U0RXD), IO15(RTS),IO13(CTS)	Devices with UART interfaces can be connected <b>Download:</b> U0TXD+U0RXD or GPIO2+U0RXD <b>Communication:</b> (UART0):U0TXD,U0RXD,MTDO(U0RTS),MTCK(U0CTS) <b>Debug:</b> UART1_TXD(GPIO2) Can be used to print debugging information
	UART1: IO2(TXD)	By default, UART0 will output some printed information when the device is powered on and is booting up. If this issue exerts influence on some specific applications, users can exchange the inner pins of UART when initializing, that is to say, exchange U0TXD, U0RXD with U0RTS, U0CTS.
I2S	I2S input: IO12 (I2SI_DATA); IO13 (I2SI_BCK ); IO14 (I2SI_WS);  I2S output: IO15 (I2SO_BCK ); IO3 (I2SO_DATA); IO2 (I2SO_WS );	Mainly used for audio capturing, processing and transmission



**5. Electrical Characteristic**

**5.1 Standby Power Consumption**

Table -3. Standby Power Consumption

Mode	Status	Typical Value
Standby	Modem Sleep	15mA
	Light Sleep	0.9mA
	Deep Sleep	20uA
	Off	0.5uA
Working ( Average )		80mA
Tx 801.11b , CCK 11Mbps , P OUT=+17 dBm		170mA
Tx 801.11g , OFDM 54Mbps , P OUT = +15 dBm		140mA
Tx 801.11n , MCS7 , P OUT = +13 dBm		120mA
Rx 801.11b , 1024 bytes packet length , -80 dBm		50mA
Rx 801.11g , 1024 bytes packet length , -70 dBm		56mA
Rx 801.11n , 1024 bytes packet length , -65 dBm		56mA

The following current consumption is based on 3.3V supply and 25°C ambient with internal regulators. Values are measured at antenna port without SAW filter. All the transmission measurements values are based on 90% duty cycle, continuous transmission mode.

Table -4. Standby Power Consumption

Mode	Status	Typical Value				
Standby	Modem Sleep	15mA				
	Light Sleep	0.9mA				
	Deep Sleep	20uA				
	Off	0.5uA				
Power Save Mode (2.4G) (Low Power Listen disabled) <sup>1</sup>	DTIM period	Current Cons. (mA)	T1 (ms)	T2 (ms)	Tbeacon (ms)	T3 (ms)
	DTIM 1	1.2	2.01	0.36	0.99	0.39
	DTIM 3	0.9	1.99	0.32	1.06	0.41

①: Modem-Sleep requires the CPU to be working, as in PWM or I2S applications. According to 802.11 standards (like U-APSD), it saves power to shut down the Wi-Fi Modem circuit while maintaining a Wi-Fi

connection with no data transmission. E.g. in DTIM3, to maintain a sleep 300mswake 3ms cycle to receive AP's Beacon packages, the current is about 15mA.

②: During Light-Sleep, the CPU may be suspended in applications like Wi-Fi switch. Without datatransmission, the Wi-Fi Modem circuit can be turned off and CPU suspended to save poweraccording to the 802.11 standard (U-APSD). E.g. in DTIM3, to maintain a sleep 300ms-wake 3mscycle to receive AP's Beacon packages, the current is about 0.9mA.

③: Deep-Sleep does not require Wi-Fi connection to be maintained. For application with long timelags between data transmission, e.g. a temperature sensor that checks the temperature every 100s,sleep 300s and waking up to connect to the AP (taking about 0.3~1s), the overall average current is less than 1mA.

## 5.2 RF Performance

Table -5. RF Performance

Description	Min	Typ	Max	Unit
Input frequency	2400	/	2483.5	MHz
Input impedance	/	50	/	ohm
Input reflection	/	/	-10	dB
PA output power at 72.2 Mbps	15.5	16.5	17.5	dBm
PA output power in 11b mode	19.5	20.5	21.5	dBm
Sensitivity				
CCK , 1Mbps	/	-98	/	dBm
CCK , 11Mbps	/	-91	/	dBm
6Mbps ( 1/2 BPSK )	/	-93	/	dBm
54Mbps ( 3/4 64-QAM )	/	-75	/	dBm
HT20 , MCS7 ( 65Mbps , 72.2Mbps )	/	-72	/	dBm
Adjacent channel rejection				
OFDM , 6Mbps	/	37	/	dB
OFDM , 54Mbps	/	21	/	dB
HT20 , MCS0	/	37	/	dB
HT20 , MCS7	/	20	/	dB

**5.3 Digital Terminal Characteristics**

Table -6. Digital Terminal Characteristics

Terminals	Symbol	Min	Max	Unit
Input logic level low	VIL	-0.3	0.25 VDD	V
Input logic level high	VIH	0.75 VDD	VDD + 0.3	V
Output logic level low	VOL	N	0.1 VDD	V
Output logic level high	VOL	0.8 VDD	N	V

**5.4 Absolute Maximum Ratings**

Table -7. Absolute Maximum Ratings

Rating	Condition	Value	Unit
Storage temperatue	/	-40 to 125	°C
Maximum soldering temperature	/	260	°C
Supply voltage	IPC/JEDEC J-STD-020	+3.0 to +3.6	V

**5.5 Reflow Profile**

Table -8. Reflow Profile

Indicator	Value
Ramp-up Rate (TS Max to TL)	3 °C /second max.
Prehea	
Temperature Min. (TS Min.)	150°C
Temperature Typ. (TS Typ.)	175°C
Temperature Min. (TS Max.)	200°C
Time (TS)	60 ~ 180 seconds
Ramp-up Rate (TL to TP)	3°C /second max
Time maintained above: Temperature (TL)/Time (TL)	270°C / 60 ~ 150 seconds
Peak temperature (TP)	260 °C max, for 10 seconds
Target Peak Temperature (TP Target)	260 °C + 0 / -5°C

Time within 5°C of actual Peak Temperature (Tp)	20 ~ 40 seconds
Ts max to TL (Ramp-down Rate)	6°C / second max.
Time 25°C to Peak Temperature (t)	8 minutes max.

**6. Schematics**

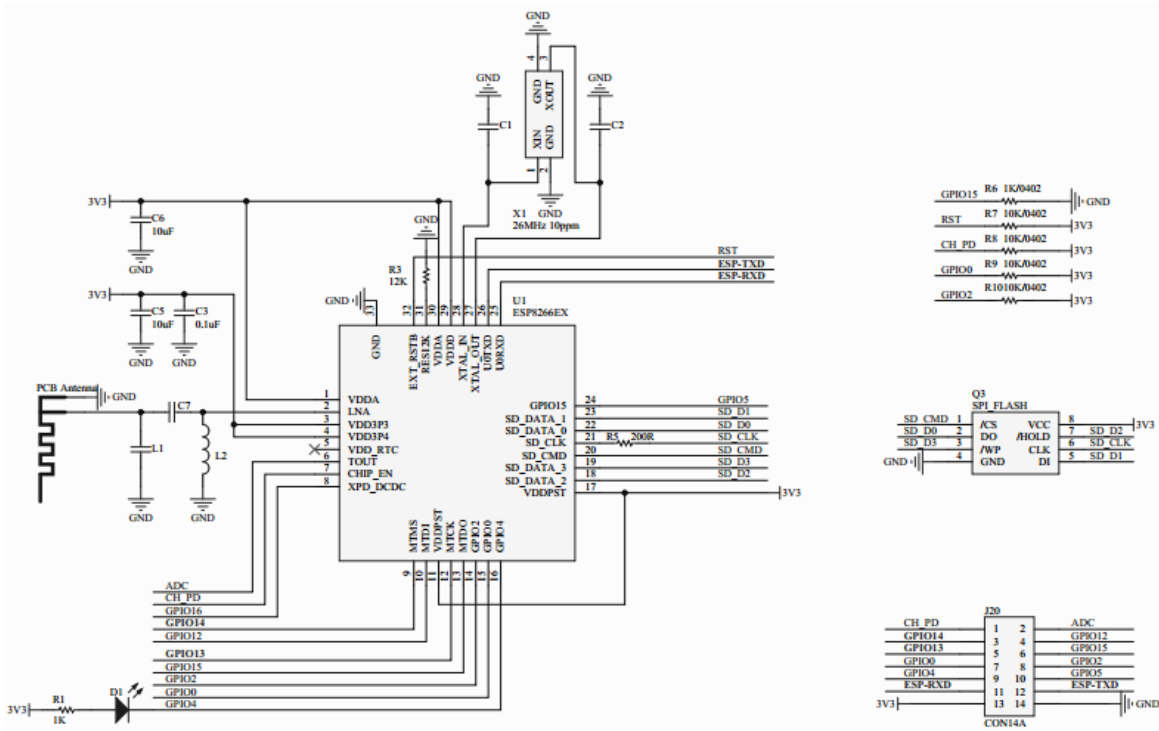

Figure -5. ESP8266-S3 Schematics

**7. Minimum System Requirements**

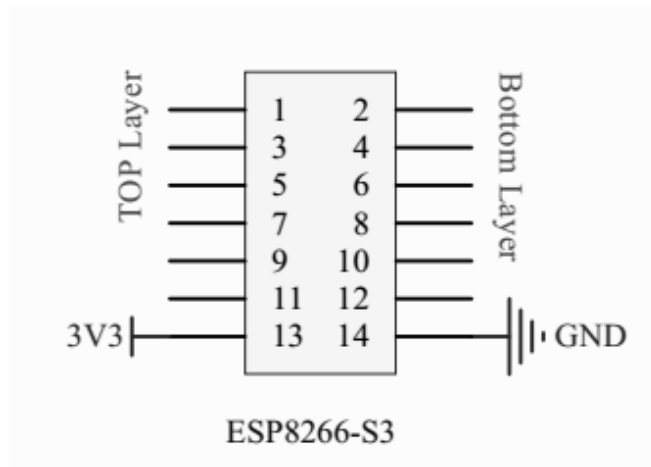

Figure -6. ESP8266-S3 minimum system

## **8. Switching noise control**

ESP8266-S3 has high speed GPIO and peripheral interfaces which can create severe switching noise. In applications where power consumption and EMI profile are important, it is recommended that a series resistor of 10-100 ohms be placed with digital I/O. This limits overshoot during switching and results in smoother transitions. A series resistor may also protect from ESD to some extents.

## **9. Technical Support**

E-mail: [technical@hysiry.com](mailto:technical@hysiry.com)

FCC Caution: Any changes or modifications not expressly approved by the party responsible for compliance could void the user's authority to operate this equipment. This device complies with Part 15 of the FCC Rules.

Operation is subject to the following two conditions: (1) This device may not cause harmful interference, and (2) this device must accept any interference received, including interference that may cause undesired operation. This device and its antenna(s) must not be co-located or operating in conjunction with any other antenna or transmitter. 15.105 Information to the user.

(b) For a Class B digital device or peripheral, the instructions furnished the user shall include the following or similar statement, placed in a prominent location in the text of the manual:

Note: This equipment has been tested and found to comply with the limits for a Class B digital device, pursuant to part 15 of the FCC Rules.

These limits are designed to provide reasonable protection against harmful interference in a residential installation. This equipment generates, uses and can radiate radio frequency energy and, if not installed and used in accordance with the instructions, may cause harmful interference to radio communications. However, there is no guarantee that interference will not occur in a particular installation. If this equipment does cause harmful interference to radio or television reception, which can be determined by turning the equipment off and on, the user is encouraged to try to correct the interference by one or more of the following measures:

- Reorient or relocate the receiving antenna.
- Increase the separation between the equipment and receiver.
- Connect the equipment into an outlet on a circuit different from that to which the receiver is connected.
- Consult the dealer or an experienced radio/TV technician for help.

**Radiation Exposure Statement:**

This equipment complies with FCC radiation exposure limits set forth for an uncontrolled environment. This transmitter must not be co-located or operating in conjunction with any other antenna or transmitter. The module should not be installed and operated simultaneously with other radios except additional RF exposure was evaluated for simultaneously transmission.

The availability of some specific channels and/or operational frequency bands are country dependent and are firmware programmed at the factory to match the intended destination.

The firmware setting is not accessible by the end user.

The final end product must be labelled in a visible area with the following:

Contains Transmitter Module FCC ID: 2AKBPESP8266-S3.